



Vitrifrigo

ICE MAKERS

Overview

IM HYDRO F1 - Upright model. Compressor in base. Requires connection to vessels water supply

IM HYDRO REFILL F1 - Upright model. Compressor in base. Internal tank replenished with bottled water.

IM HYDRO XT F1 - Low profile model. Compressor at rear. Requires connection to vessels water supply.



All models also available in Black or White

IM Hydro F1 and IM Refill F1

110v 60Hz (230v 60Hz available)

IM Hydro XT F1

110v 60Hz (230v 60Hz available)

SPECIFICATIONS

Model	<u>IM Hydro and IM Refill</u>
Volume	0.8 cu ft
Power	115v 60Hz
Condensing Unit	Internal - In Base
Weight	55.1 Lbs
Ice Production	26lbs/24hr
Nominal Input	117 watts
Rated Current	1.75 amp
Mounting	Flush flange
Mounting Option	Bottom Trim Piece
Finish	Stainless steel - Mirror
Finish Option	Stainless steel - Brushed

Model	<u>IM Hydro XT</u>
Volume	0.8 cu ft
Power	115v 60Hz
Condensing unit	Internal - At Rear
Weight	57.3 lbs
Ice Production	26lbs/24hr
Nominal Input	117 watts
Rated Current	1.75 amp
Mounting	Flush Flange
Mounting Option	Bottom Trim Piece
Finish	Stainless Steel - Mirror
Finish Option	Stainless Steel - Brushed

Dimensional data over:



Vitrifrigo

Dimensional Data

IM HYDRO F1 and IM HYDRO REFILL F1

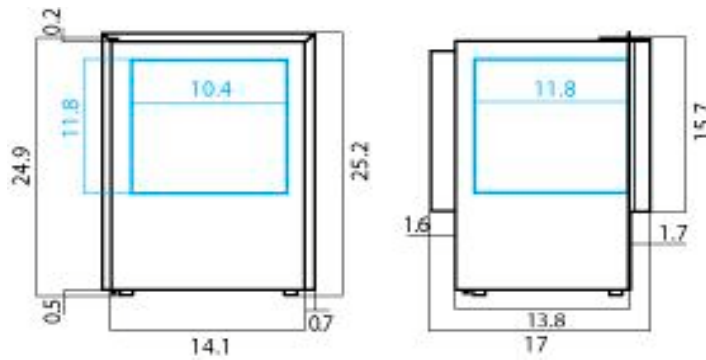

IM HYDRO XT F1

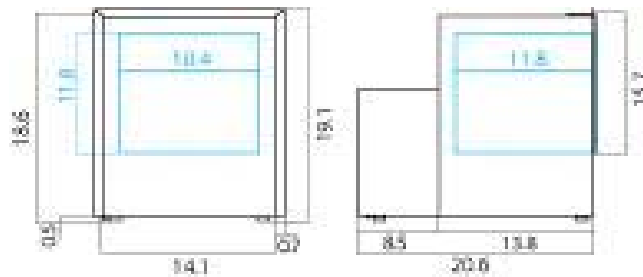

These and other Vitrifrigo models available from:



Coastal Climate Control, Inc.

4831 Telsa Drive - Suite H, Bowie MD 20715

Ph. 301-352-5738

info@coastalclimatecontrol.com

www.coastalclimatecontrol.com